

Uniblitz® FS35

35mm Uni-Stable Optical Shutter



Overview

The Uniblitz FS series shutters are designed and optimized to operate directly from +5VDC and do not require a separate driver. Removing the +5VDC (0VDC) closes these shutters. A simple control circuit can be used to operate these shutter devices from a TTL trigger pulse. This control can be also accomplished with our new VLM1 TTL control interface (available soon).

This low-cost innovation provides the reliability of Uniblitz shutters (typical lifetime >300K cycles) at a single operating voltage.

Need Support? Please [visit our website](#) or email us at info@uniblitz.com.

Tel: 585-385-5930 | Toll-Free: 800-828-6972 | Fax: 585-385-6004 | 803 Linden Ave. Rochester, NY 14625

Updated 11/19 | Datasheet Version 5.0 | ©2019 Vincent Associates

Key Features

- 35mm aperture
- Default closed operation, +5VDC opens the shutter, 0VDC closes the shutter
- **RoHS Compliant**
- Transfer time on opening:
20.0 milliseconds
- Total opening time:
32.0 milliseconds

Product Options

FS35 2 3 4 5 6 - 7

Ex: FS35S2C0L-EC

1 Shutter Series:

- **FS35:** Normally Closed
- **FSR35:** Normally Open

3 Housing:

- **1:** Un-Housed
- **2:** Half-Housed
- **3:** Fully-Housed

5 Electronic Sync:

- **0:** Omitted
- **1:** Included

7 Encapsulated Coil:

- **EC:** Included
- Leave blank if not required

2 Voltage:

- **S:** Standard 5VDC

4 Blades: ¹

- **C:** Black carbon impregnated plastic (C-PET)
- **T:** Low Energy (Teflon[®])
- **ZM:** High Energy (AlMgF₂) ²

6 Connector:

- **L:** 18" flying leads

¹ Other blade coating options may be available by special order.

² Input side only; Teflon[®] coating is on opposite side to protect shutter blade surface. Light source must be input to the reflective side only.

Shutter Timing

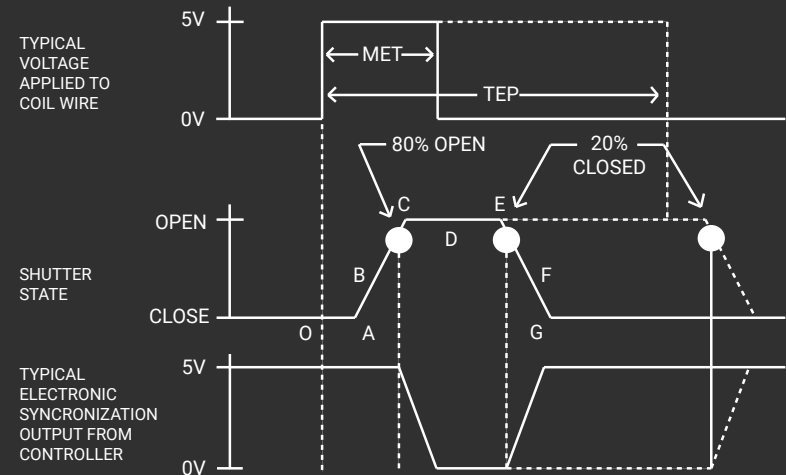

FS35 (w/ 5VDC and C-PET blades)

Time (msec.)

O - A	Delay time on opening after current applied	12.0
A - C	Transfer time on opening	20.0
O - C	Total opening time	32.0
C - E	Min. dwell time with min. input pulse	5.0
B - F	Min. equivalent exp. time	24.0
E - G	Transfer time on closing	18.0
A - G	Total window time	43.0
MET	Min. exposure time	30.0
TEP	Typical exposure pulse	>30.0

Technical Specifications

Coil Resistance	Voltage to Open	Hold Voltage
12 Ω	+5 VDC	+5 VDC

¹(Continuous/Burst) Continuous frequency rating specified at shutter's minimum exposure pulse. Burst frequency rating specified for four (4) seconds maximum with one (1) minute minimum between bursts.

Series	Weight (Unhoused/Half/Housed)	Operating Temp.	Max. Opening Bounce	Max. Closing Bounce	Max. Freq. of Operation ¹	Number of Shutter Blades
FS35	48.5 g / 116.0 g / 183.5 g	-40 - +65 °C	15%	15%	5 Hz / 10 Hz	5

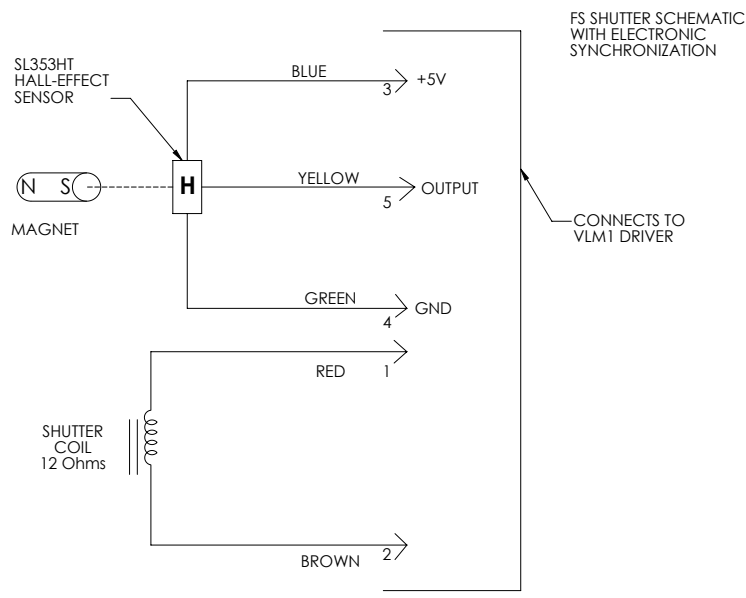

The synchronization system for FS shutter devices incorporates a small magnet mounted to the driving mechanism and a Hall effect sensor. When the device achieves approximately 80% of full open, the magnet causes the Hall effect sensor to change state, producing a signal to indicate that the shutter has switched to the active state. Shown to the left is the FS series shutter schematic which incorporates the electronic synchronization system. **There is no connection to the designated synchronization pins when an electronic sync. is not selected.**

Technical Drawings - FS35 (Half-Housed - FS35S2C0L)

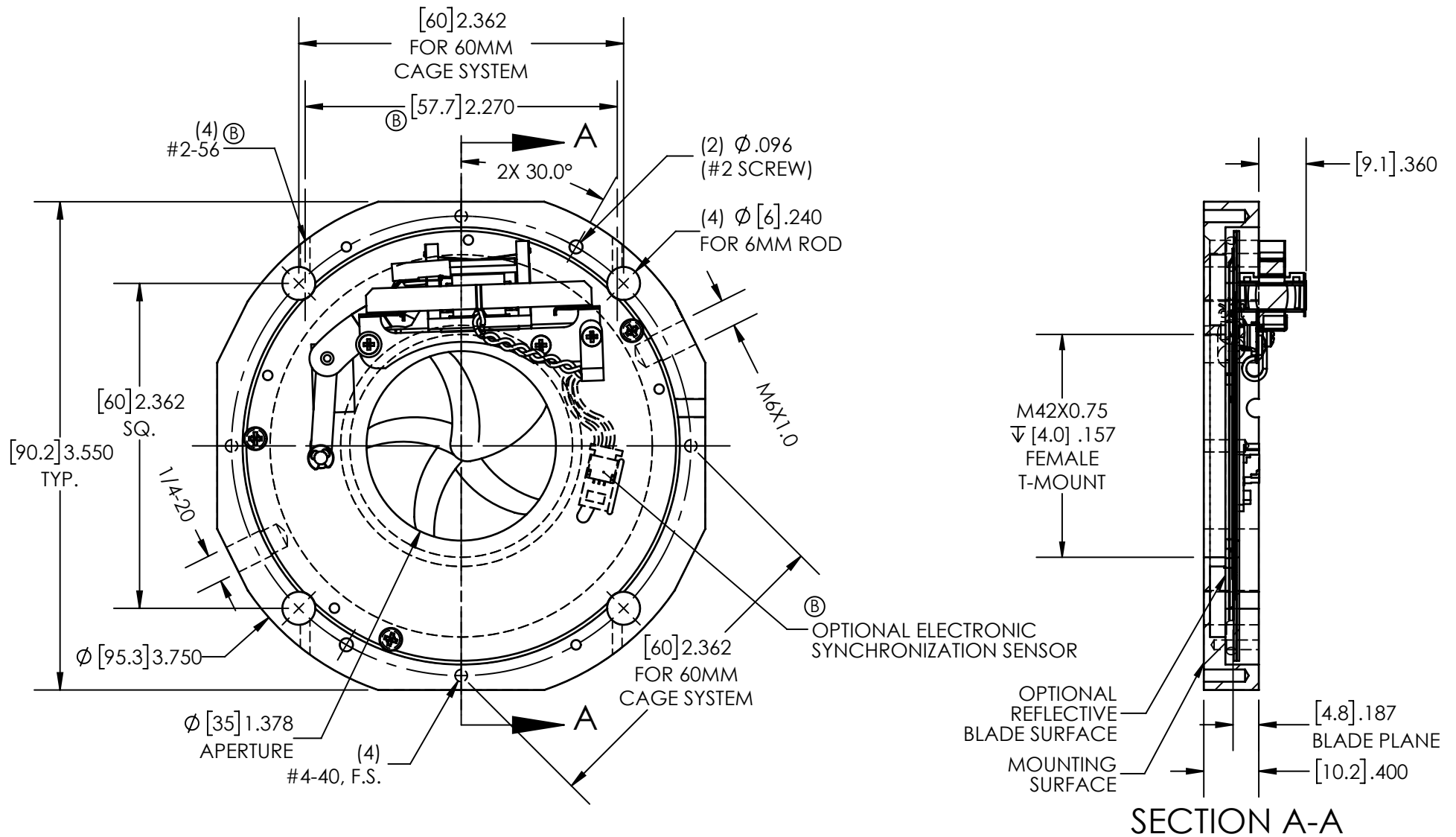

NOTES:

1. UNITS: [MM] INCH.
2. LIMITED HIDDEN LINES SHOWN FOR CLARITY.
3. LEADS WIRES REMOVED FOR CLARITY.

Technical Drawings - FS35 (Un-Housed - FS35S1C0L)

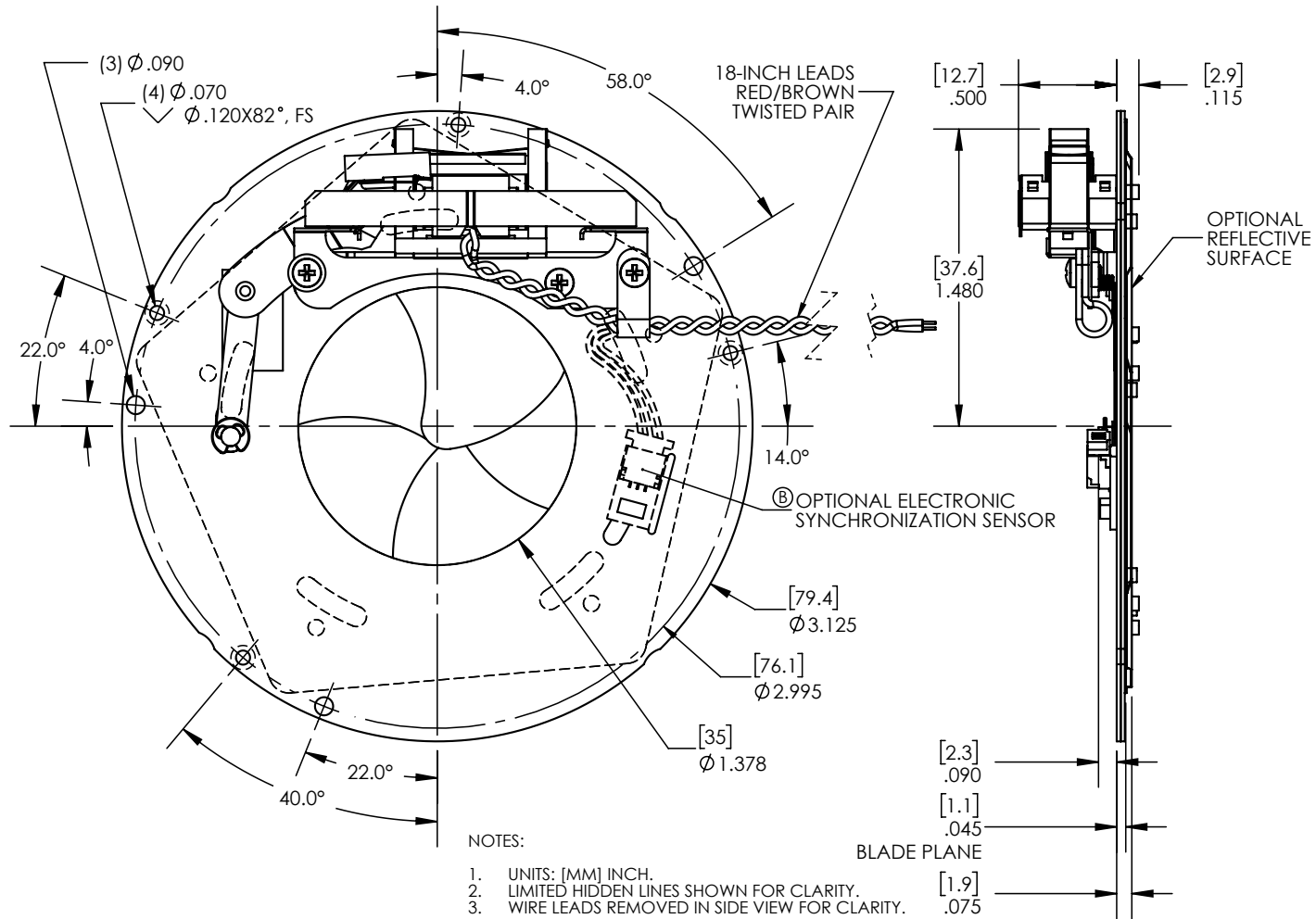

Technical Drawings - FS35 (Housed - FS35S3C0L)

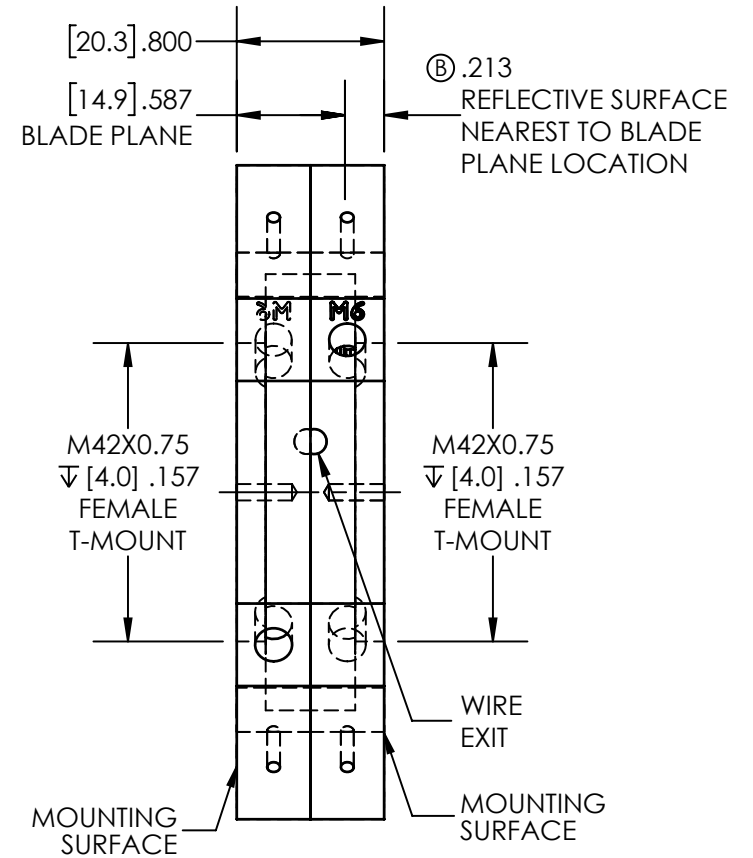
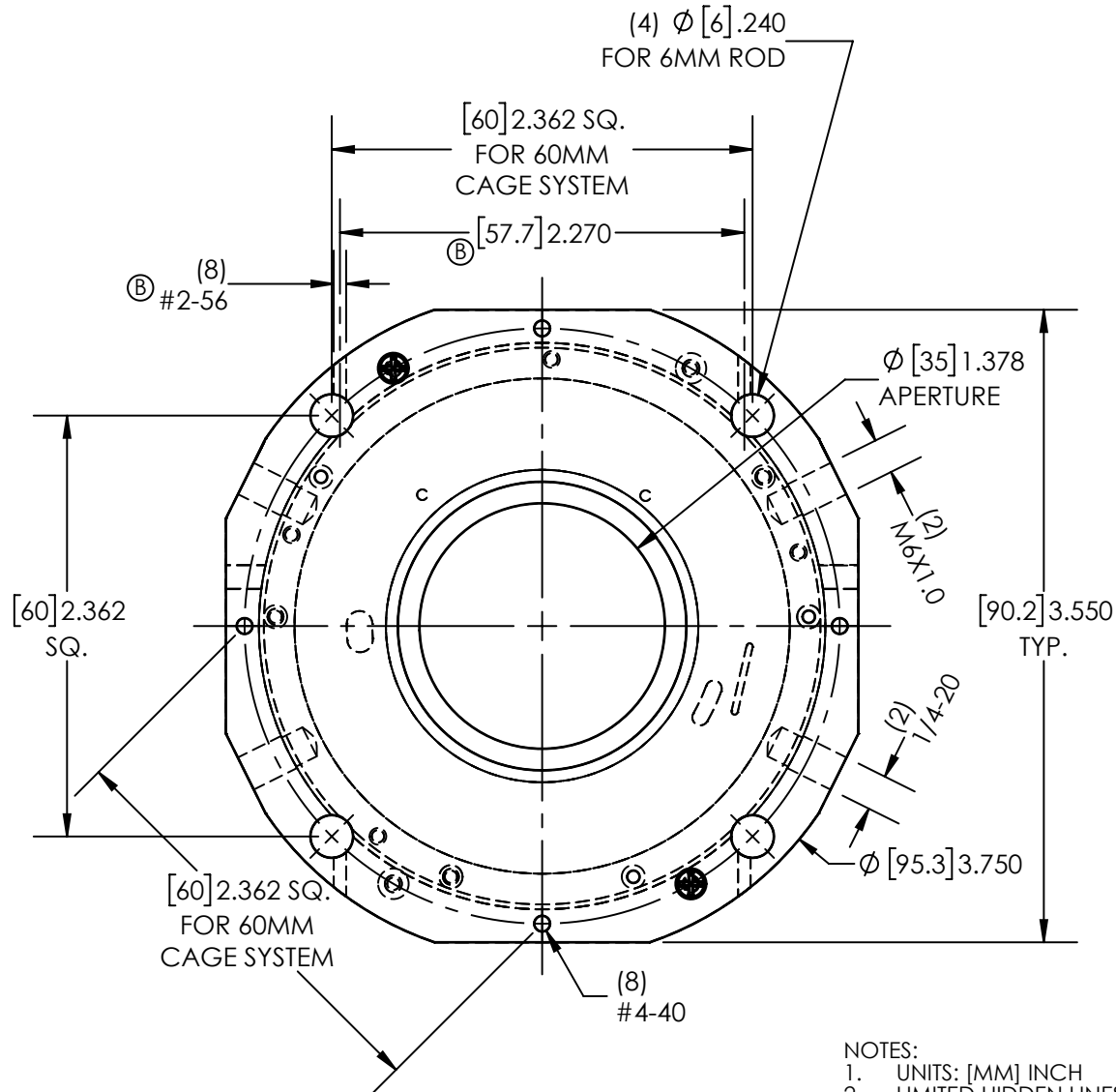

NOTES:

1. UNITS: [MM] INCH
2. LIMITED HIDDEN LINES SHOWN FOR CLARITY.
3. OPTIONAL REFLECTIVE SURFACE OPPOSITE ACTUATOR COIL SIDE.